

POCKET DOOR HARDWARE (INSET)

ALT-2V-220

SLIDING & FOLDING DOOR HARDWARE

POCKET DOOR HARDWARE



PAT

- Opening door is stored inside the cabinet
- Recommend the use of 230-C26/OT (Page ***) in this system
- Inset
- One touch door installation & removal

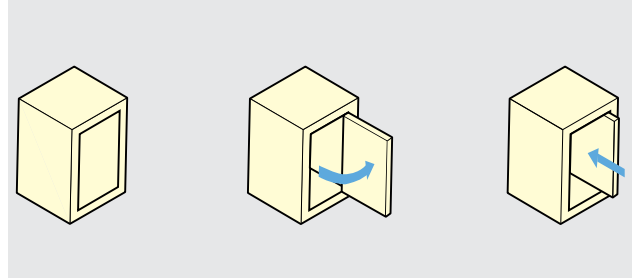

Item No.	ALT-2V-220S-16~28 S-Type	ALT-2V-220M-16~28 M-Type	ALT-2V-220L-16~28 L-Type	ALT-2V-220LL-16~28 LL-Type
Door Width	Max. 560mm	Max. 560mm	Max. 560mm	Max. 600mm
Door Height	820~1060mm	1240~1500mm	1640~1840mm	1980~2300mm
Door Weight	Max. 5kg	Max. 6kg	Max. 8kg	Max. 10kg

PRODUCT Info.

Item No.	Max. Door width (mm)	Door Height (mm)	Max. Door Weight (kg)	Min. Cabinet Depth (mm)
ALT-2V-220S-16	560	820 - 1060	5	412 + Door Thickness
ALT-2V-220S-19				488 + Door Thickness
ALT-2V-220S-22				564 + Door Thickness
ALT-2V-220S-24				615 + Door Thickness
ALT-2V-220S-28				717 + Door Thickness
ALT-2V-220M-16	560	1240 - 1500	6	412 + Door Thickness
ALT-2V-220M-19				488 + Door Thickness
ALT-2V-220M-22				564 + Door Thickness
ALT-2V-220M-24				615 + Door Thickness
ALT-2V-220M-28				717 + Door Thickness
ALT-2V-220L-16	560	1640 - 1840	8	412 + Door Thickness
ALT-2V-220L-19				488 + Door Thickness
ALT-2V-220L-22				564 + Door Thickness
ALT-2V-220L-24				615 + Door Thickness
ALT-2V-220L-28				717 + Door Thickness
ALT-2V-220LL-16	600	1980 - 2300	10	412 + Door Thickness
ALT-2V-220LL-19				488 + Door Thickness
ALT-2V-220LL-22				564 + Door Thickness
ALT-2V-220LL-24				615 + Door Thickness
ALT-2V-220LL-28				717 + Door Thickness

Parts Qty. for each item no.

Rail	Hinge	Mounting Plate	Connecting Plate	Parts set	Catch
2	2	2	1	1	1
3	3	3			
3	3	3			
3	3	3			
4	4	4			

* Item No. is for one door unit.

Preparation

Door Storing

- 16 inch - 269 + Door Thickness (270 + Door Thickness)
- 19 inch - 345 + Door Thickness (346 + Door Thickness)
- 22 inch - 421 + Door Thickness (422 + Door Thickness)
- 24 inch - 472 + Door Thickness (473 + Door Thickness)
- 28 inch - 574 + Door Thickness (575 + Door Thickness)

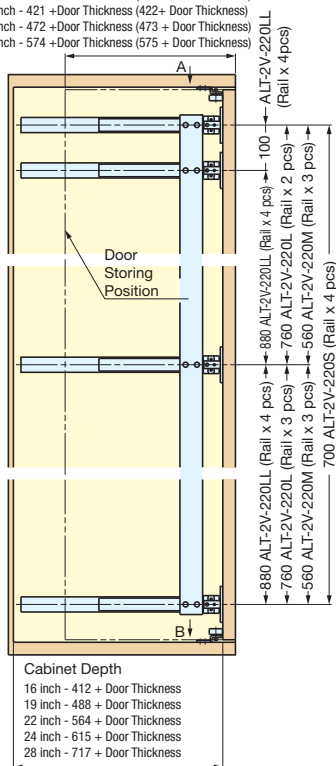

Connecting Plate

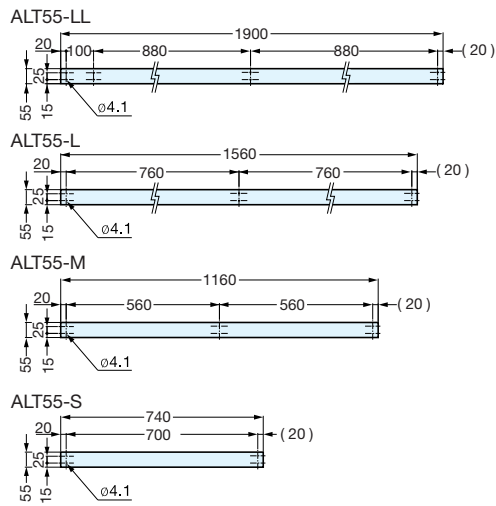

Door Boring Dimension

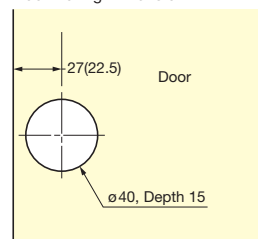

Installation

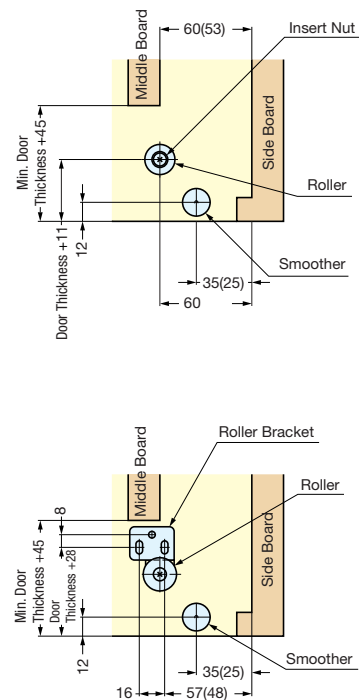
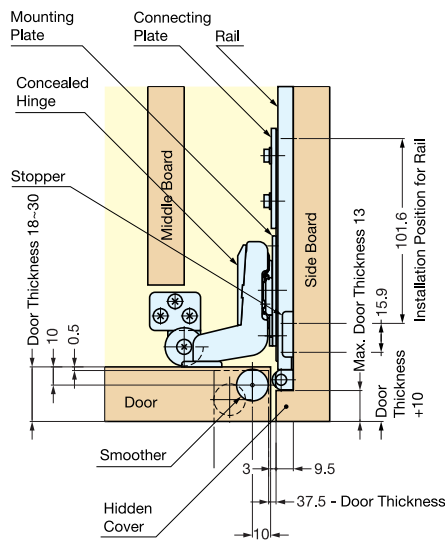
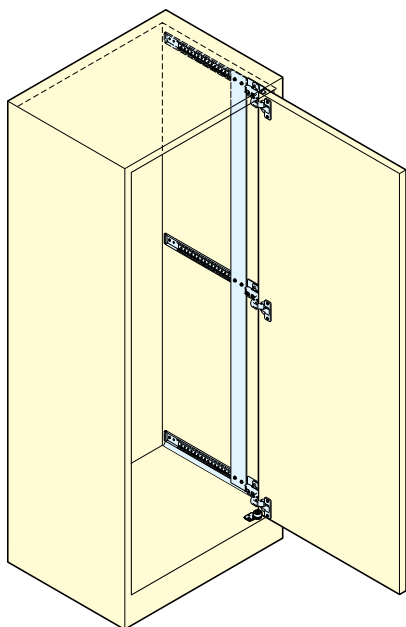

■ Installation - Rail

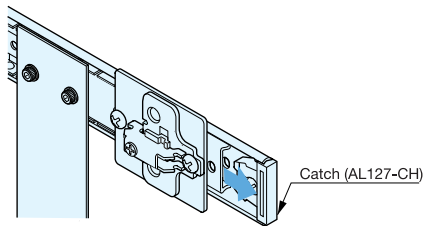
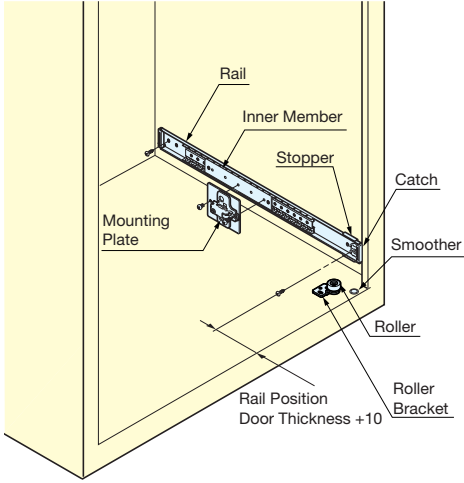

1. Lap rail over stopper and install together
2. Screw for the rail is temporarily fastened first
3. Install the mounting plate

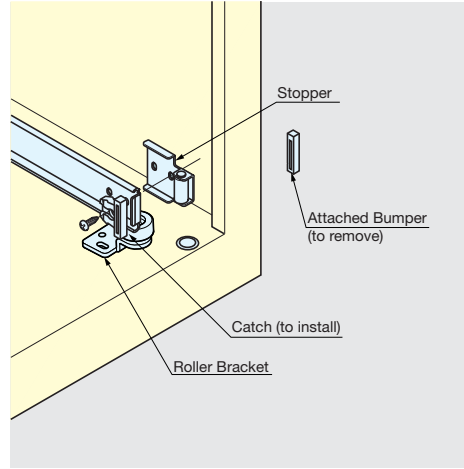



Item No.	Part Name
AL127-CH	Catch

■ Installation - Guide (ALT-BR) - Option Parts

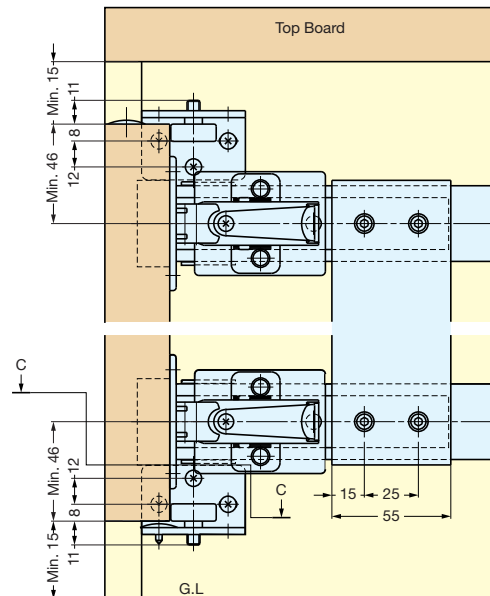
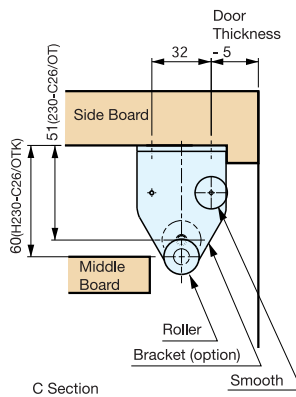
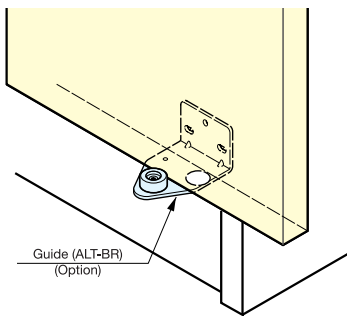
- Guide for side board installation
- Recommended to install 1 pc each for both upper and lower boards

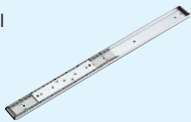

Item No.	Part Name
ALT-BR	Guide

No.	Part Name	Description	Item No.
1		Material: Steel Finish: Chrome	AL127C-16
			AL127C-19
			AL127C-22
			AL127C-24
			AL127C-28
2		Material: Aluminium Finish: Steel	ALT55-S
			ALT55-M
			ALT55-L
			ALT55-LL
3		Material: Steel Finish: Nickel	H230-C26/0T
4		Material: Steel Finish: Nickel	ALT-MP
5		Material: Polyurethane Colour: Black	AL127-CH
6 (PARTS SET)		Material: EPDM Rubber/Steel Finish: White/Chrome	ALT-2V-220SP
		Material: Steel Finish: Chrome	
		Material: Polyamide Colour: White	
		Material: Polyethylene Colour: White	
		Material: Steel Finish: Chrome	
		Material: Urethane Steel Finish: Chrome/Black	

OPTION

Part Name	Description	Item No.
	Material: Steel Finish: Yellow Zinc Chromate	ALT-BR

DETAILS FOR PARTS SET

Item No.	Roller	Roller Bracket	Insert Nut	Smoother	Stopper
ALT-2V-SSP	2 pcs	Each 1 pc (L & R)	2 pcs	2 pcs	2 pcs
ALT-2V-220LP	2 pcs	Each 1 pc (L & R)	2 pcs	2 pcs	3 pcs
ALT-2V-220LLP	2 pcs	Each 1 pc (L & R)	2 pcs	2 pcs	4 pcs